

HART,
Pt100 (RTD), thermocouples,
Electrical isolation

■ Input

- Resistance thermometers
- Thermocouples
- Resistance-type transmitter (0 ... 5000 Ω)
- Voltages, mV transmitter (-125 ... 1100 mV)

■ Output

- 2-wire technique
- 4 ... 20 mA temperature linear
- HART signal

■ Measurement error

- 0.1 K

■ Continuous sensor and self-monitoring

- 2-function LEDs
- Supply voltage monitoring
- Wire break and corrosion monitoring (NE 89)

■ Unit software acc. to NE 53

■ Approvals for explosion protection

- Intrinsic Safety: ATEX EEx ia (Zone 0)
- non-incendive: ATEX EEx n A

■ Configuration

- FDT/DTM
- SMART VISION DSV401
- EDD



HART
COMMUNICATION PROTOCOL

2-function LEDs
Sensor matching
Hardware write protection

ABB

Contents

1	Technical data	3
1.1	Input.....	3
1.2	Output.....	3
1.3	Power supply (polarity safe).....	4
2	General information	4
2.1	Ambient conditions	4
2.2	Electromagnetic compatibility.....	4
2.3	EMI/RFI shielding	4
2.4	Measuring accuracy	5
2.5	Operating conditions	7
2.6	Mechanical design.....	8
3	Communication	8
4	Explosion-protection relevant information	8
4.1	TTR200-E1... (intrinsically safe)	8
4.2	TTR200-E2... (non-incendive)	9
5	Approvals	9
6	Terminal connection diagrams	10
7	Dimensional drawings	10
8	Ordering information	11
9	Order form configuration	12

1 Technical data

1.1 Input

1.1.1 Resistance

RTD resistance thermometer

Pt100 in acc. with DIN IEC 60751, JIS, MIL, Ni in acc. with
DIN 43760, Cu

(for additional information, see the section "Measuring accuracy")

Resistance measurement

0 ... 500 Ω

0 ... 5000 Ω

Sensor connections

2-, 3-, 4-wire circuit

Connecting cables

2-, 3-, 4-wire max. sensor line resistance (R_W) for each wire 50 Ω
in acc. with NE 89 (March 2003);

(3-wire balanced, 2-wire circuit compensation up to 100 Ω sensor
total line resistance)

Measurement current

< 300 μ A

Sensor short-circuit

< 5 Ω (for RTD)

Sensor wire break (temperature resistance measurement 2-, 3-, 4-wire)

Measuring range 0 ... 500 Ω > 0.6 ... 10 k Ω

Measuring range 0 ... 5 k Ω > 5.3 ... 10 k Ω

Corrosion detection in accordance with NAMUR NE 89

3-wire resistance reading > 50 Ω

4-wire resistance reading > 50 Ω

1.1.2 Thermocouples/Voltages

Types

B, E, J, K, L, N, R, S, T, U, C, D

Voltages

-125 ... 125 mV

-125 ... 1100 mV

Connecting cables

Max. sensor line resistance (R_W) for each line 1.5 k Ω , total 3 k Ω

Sensor wire break monitoring in accordance with Namur NE 89

pulsed with 1 μ A outside the measurement interval

Thermocouple measurement 5.3 ... 10 k Ω

Voltage measurement 5.3 ... 10 k Ω

Input resistance

> 10 M Ω

Internal reference junction

Pt1000, DIN IEC 60751 Cl. B

(no jumpers necessary)

Sensor matching

via single point (offset adjustment)

via two point adjustment

Sensor fault signaling

RTD sensor: Short circuit and wire break

Linear resistance measurement: Wire break

Thermocouple: Wire break

Linear voltage measurement: Wire break

1.2 Output

Transmission characteristics

temperature linear

resistance linear

voltage linear

Output signal

Configurable 4 ... 20 mA (standard)

Configurable 20 ... 4 mA

(NE43 dynamic range: 3.8 ... 20.5 mA)

Simulation mode

3.5 ... 23.6 mA

Induced current consumption

< 3.5 mA

Maximum output current

23.6 mA

Configurable error current signal

override 22 mA (20.0 ... 23.6 mA)

underdrive 3.6 mA (3.5 ... 4.0 mA)

1.3 Power supply (polarity safe)

(2-wire technique; power lines = signal lines)

Supply voltage

Non ignition-proof application:

$$U_s = 12 \dots 42 \text{ V DC}$$

Ignition-proof applications:

$$U_s = 12 \dots 30 \text{ V DC}$$

Max. permissible residual ripple for supply voltage

Max. permissible ripple for supply voltage during communication in accordance with HART FSK "Physical Layer" specification, version 8.1 (08/1999) Section 8.1

Undervoltage detection

$$U_{\text{Terminal-Mu}} < 11 \text{ V results in } I_a = 3.6 \text{ mA}$$

Max. load

$$R_{\text{Load}} = (\text{supply voltage} - 12 \text{ V}) / 0.022 \text{ A}$$

Max. load (Ω depending on supply voltage (V DC))

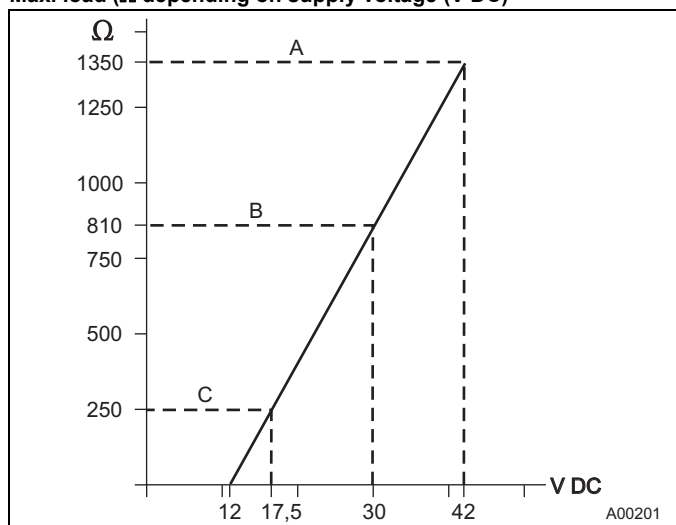

Fig. 1

- A TTR200
- B TTR200 in EEx ia design
- C HART communication - resistor

Max. power consumption

$$P = U_s \times 0.022 \text{ mA}$$

e.g., $U_s = 24 \text{ V} \rightarrow P_{\text{max}} = 0.528 \text{ W}$

2 General information

Electrical isolation (input/output)	3.5 kV DC (approx. 2.5 kV AC) 60 s
MTBF time	28 years at 60 °C ambient temperature
Input filter	50 / 60 Hz
Switch-on delay	< 10 s ($I_a \leq 3.6 \text{ mA}$ during starting cycle)
Warm-up time	5 min.
Ramp-up time t90	400 ... 1000 ms
Reading updated¹⁾	10/sec
Output filter	Digital filter 1st order: 0 ... 100 s

¹⁾ depending on sensor type and sensor circuit

2.1 Ambient conditions

Ambient temperature: Standard: -40 ... 85 °C / -40 ... 185 °F
For ignition-proof design, see prototype test certificate PTB 05 ATEX 2017 X.

Transport / storage temperature: -40 ... 85 °C / -40 ... 185 °F

Climate class: Cx (-40 ... 85 °C / -40 ... 185 °F, 5 ... 95% relative humidity)
DIN EN 60654-1

Max. permissible humidity: 95% relative humidity IEC 60068-2-30

Vibration resistance*: 10 ... 2000 Hz at 5 g acc. to IEC 68-2-6

Shock*: gn = 30 in accordance with IEC 68-2-27

Protection class: IP20, or IP class of bay

* applies to operation and transport

2.2 Electromagnetic compatibility

Emitted interference in accordance with IEC 61326 (2006) and Namur NE21 (02/2004)

2.3 EMI/RFI shielding

Interference immune in accordance with IEC 61326 (2006) and Namur NE21 (02/2004)

Pt100: Measuring range 0 ... 100 °C, span 100 K

Type of test	Testing accuracy	Influence
Burst to signal/data lines	2 kV	< 0,5%
Static discharge		
• Contact plate (indirect)	8 kV	no
• Supply terminals ¹⁾	6 kV	no
• Sensor terminals ¹⁾	4 kV	no
Radiated field		
80 MHz ... 2 GHz	10 V / m	< 0,5%
Coupling		
150 kHz ... 80 MHz	10 V	< 0,5%
Surge between the supply lines	0,5 kV	no malfunction
Line to earth	1 kV	no malfunction

¹⁾ Air discharge (at 1 mm distance)

2.4 Measuring accuracy

Includes linearity deviation, reproducibility/hysteresis at 23 °C ± 5 K and 20 V supply voltage

Information on measuring accuracy corresponds to 3 σ (Gaussian distribution)

Input element		Measuring range limits	Minimum span	Digital measuring accuracy (24-bit A/D converter)	D/A accuracy ¹⁾ (1 6-bit DA)
Standard	Sensor				
Resistance sensors/potentiometer					
DIN IEC 60 751	RTD Pt10 (a=0,003850)	-200 ... 850 °C / -328 ... 1562 °F	10 °C / 18 °F	± 0,80 °C / ± 1,44 °F	± 0,05 %
	RTD Pt50 (a=0,003850)	-200 ... 850 °C / -328 ... 1562 °F	10 °C / 18 °F	± 0,16 °C / ± 0,29 °F	± 0,05 %
	RTD Pt100 (a=0,003850) ²⁾	-200 ... 850 °C / -328 ... 1562 °F	10 °C / 18 °F	± 0,08 °C / ± 0,14 °F	± 0,05 %
	RTD Pt200 (a=0,003850)	-200 ... 850 °C / -328 ... 1562 °F	10 °C / 18 °F	± 0,24 °C / ± 0,43 °F	± 0,05 %
	RTD Pt500 (a=0,003850)	-200 ... 850 °C / -328 ... 1562 °F	10 °C / 18 °F	± 0,16 °C / ± 0,29 °F	± 0,05 %
	RTD Pt1000 (a=0,003850)	-200 ... 850 °C / -328 ... 1562 °F	10 °C / 18 °F	± 0,08 °C / ± 0,14 °F	± 0,05 %
JIS C1604-81	RTD Pt10 (a=0,003916)	-200 ... 645 °C / -328 ... 1193 °F	10 °C / 18 °F	± 0,80 °C / ± 1,44 °F	± 0,05 %
	RTD Pt50 (a=0,003916)	-200 ... 645 °C / -328 ... 1193 °F	10 °C / 18 °F	± 0,16 °C / ± 0,29 °F	± 0,05 %
	RTD Pt100 (a=0,003916)	-200 ... 645 °C / -328 ... 1193 °F	10 °C / 18 °F	± 0,08 °C / ± 0,14 °F	± 0,05 %
MIL-T-24388	RTD Pt10 (a=0,003920)	-200 ... 850 °C / -328 ... 1562 °F	10 °C / 18 °F	± 0,80 °C / ± 1,44 °F	± 0,05 %
	RTD Pt50 (a=0,003920)	-200 ... 850 °C / -328 ... 1562 °F	10 °C / 18 °F	± 0,16 °C / ± 0,29 °F	± 0,05 %
	RTD Pt100 (a=0,003920)	-200 ... 850 °C / -328 ... 1562 °F	10 °C / 18 °F	± 0,08 °C / ± 0,14 °F	± 0,05 %
	RTD Pt200 (a=0,003920)	-200 ... 850 °C / -328 ... 1562 °F	10 °C / 18 °F	± 0,24 °C / ± 0,43 °F	± 0,05 %
	RTD Pt1000 (a=0,003920)	-200 ... 850 °C / -328 ... 1562 °F	10 °C / 18 °F	± 0,08 °C / ± 0,14 °F	± 0,05 %
DIN 43760	RTD Ni50 (a=0,006180)	-60 ... 250 °C / -76 ... 482 °F	10 °C / 18 °F	± 0,16 °C / ± 0,29 °F	± 0,05 %
	RTD Ni100 (a=0,006180)	-60 ... 250 °C / -76 ... 482 °F	10 °C / 18 °F	± 0,08 °C / ± 0,14 °F	± 0,05 %
	RTD Ni120 (a=0,006180)	-60 ... 250 °C / -76 ... 482 °F	10 °C / 18 °F	± 0,08 °C / ± 0,14 °F	± 0,05 %
	RTD Ni1000 (a=0,006180)	-60 ... 250 °C / -76 ... 482 °F	10 °C / 18 °F	± 0,08 °C / ± 0,14 °F	± 0,05 %
	RTD Cu10 (a=0,004270)	-50 ... 200 °C / -58 ... 392 °F	10 °C / 18 °F	± 0,80 °C / ± 1,44 °F	± 0,05 %
	RTD Cu100 (a=0,004270)	-50 ... 200 °C / -58 ... 392 °F	10 °C / 18 °F	± 0,08 °C / ± 0,14 °F	± 0,05 %
	Resistance measurement	0 ... 500 Ω	4 Ω	± 32 mΩ	± 0,05 %
	Resistance measurement	0 ... 5000 Ω	40 Ω	± 320 mΩ	± 0,05 %
Thermocouples³⁾/voltages					
IEC 584	Type K (Ni10Cr-Ni5)	-270 ... 1372 °C / -454 ... 2502 °F	50 °C / 90 °F	± 0,35 °C / ± 0,63 °F	± 0,05 %
	Type J (Fe-Cu45Ni)	-210 ... 1200 °C / -346 ... 2192 °F	50 °C / 90 °F	± 0,35 °C / ± 0,63 °F	± 0,05 %
	Type N (Ni14CrSi-NiSi)	-270 ... 1300 °C / -454 ... 2372 °F	50 °C / 90 °F	± 0,35 °C / ± 0,63 °F	± 0,05 %
	Type T (Cu-Cu45Ni)	-270 ... 400 °C / -454 ... 752 °F	50 °C / 90 °F	± 0,35 °C / ± 0,63 °F	± 0,05 %
	Type E (Ni10Cr-Cu45Ni)	-270 ... 1000 °C / -454 ... 1832 °F	50 °C / 90 °F	± 0,35 °C / ± 0,63 °F	± 0,05 %
	Type R (Pt13Rh-Pt)	-50 ... 1768 °C / -58 ... 3215 °F	100 °C / 180 °F	± 0,95 °C / ± 1,71 °F	± 0,05 %
	Type S (Pt10Rh-Pt)	-50 ... 1768 °C / -58 ... 3215 °F	100 °C / 180 °F	± 0,95 °C / ± 1,71 °F	± 0,05 %
	Type B (Pt30Rh-Pt6Rh)	-0 ... 1820 °C / +32 ... 3308 °F	100 °C / 180 °F	± 0,95 °C / ± 1,71 °F	± 0,05 %
DIN 43710	Type L (Fe-CuNi)	-200 ... 900 °C / -328 ... 1652 °F	50 °C / 90 °F	± 0,35 °C / ± 0,63 °F	± 0,05 %
	Type U (Cu-CuNi)	-200 ... 600 °C / -328 ... 1112 °F	50 °C / 90 °F	± 0,35 °C / ± 0,63 °F	± 0,05 %
ASTM E 988	Type C	-0 ... 2315 °C / +32 ... 4200 °F	100 °C / 180 °F	± 1,35 °C / ± 2,43 °F	± 0,05 %
	Type D	-0 ... 2315 °C / +32 ... 4200 °F	100 °C / 180 °F	± 1,35 °C / ± 2,43 °F	± 0,05 %
	Voltage measurement	-125 mV ... 125 mV	2 mV	± 12 μV	± 0,05 %
	Voltage measurement	-125 mV ... 1100 mV	20 mV	± 120 μV	± 0,05 %

¹⁾ percentages refer to the configured measuring span

²⁾ Standard model

³⁾ include the internal reference junction error for digital accuracy: Pt100, DIN IEC 60751 Cl. B

⁴⁾ without reference junction error

Total accuracy = digital measuring accuracy [°C] + (D/A measuring accuracy [%] x | conf. measuring span [°C] | /100%)

(refer to the block diagram on next page)

Example 1:

Pt100 (IEC 60751), conf. measuring range 0 ... 100 °C, conf. measuring span = measurement end – measurement start = 100 °C

Digital measuring accuracy: ± 0,08 °C

D/A measuring accuracy ± 0.05% x (100 °C/100%) = ± 0,05 °C

Total accuracy: Digital accuracy + D/A accuracy; ± 0,08 °C + (± 0,05 °C) = ± 0,13 °C

Example 2:

Thermocouple type K, conf. measuring range 0 ... 1000 °C, conf. measuring span = measurement end – measurement start = 1000 °C

Digital measuring accuracy: ± 0,35 °C

D/A measuring accuracy ± 0.05% x (1000 °C/100%) = ± 0,50 °C

Total accuracy⁴⁾: Digital accuracy + D/A accuracy; ± 0,35 °C + (± 0,50 °C) = ± 0,85 °C

Long-term drift

± 0.05 °C or ± 0.05%¹⁾ per year, the larger value applies.

2.4.1 Block diagram

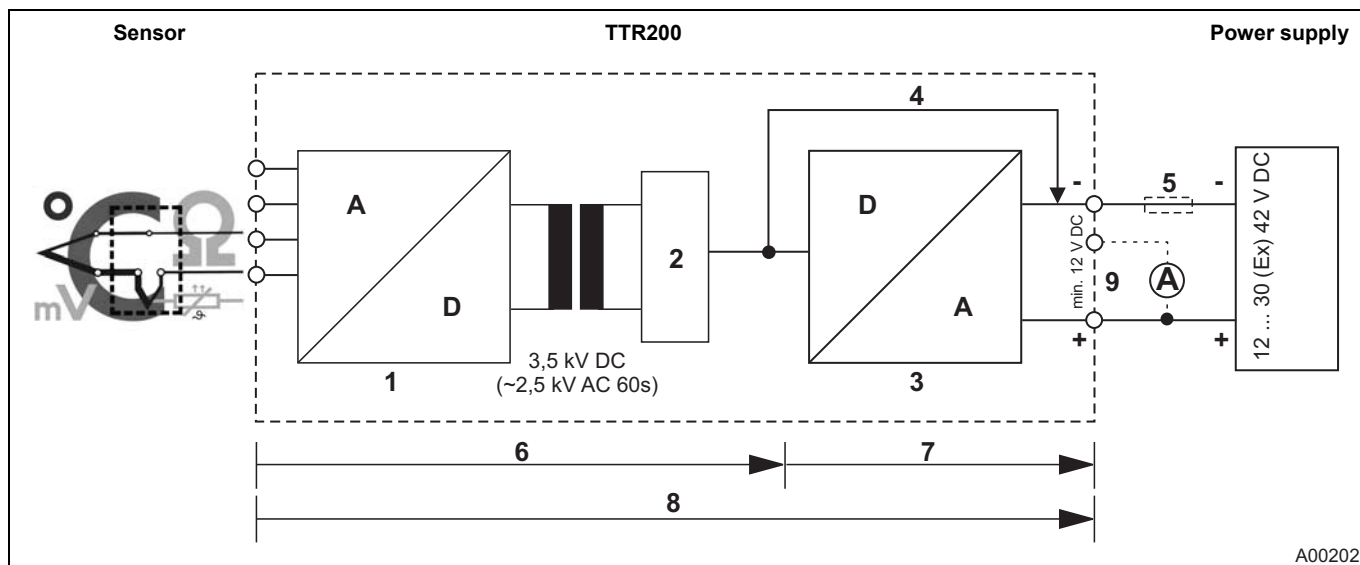

A00202

Fig. 2

- | | |
|--|--|
| <ul style="list-style-type: none"> 1 24-bit A/D converter 2 Microcontroller 3 16-bit D/A converter 4 HART signal 5 Load (observe voltage drop, refer to the section "Terminal connection diagrams") | <ul style="list-style-type: none"> 6 Digital measuring accuracy 7 D/A measuring accuracy 8 Overall measuring accuracy 9 Terminal 11, measurement of 4 ... 20 mA output current without opening / interrupting the current loop (internal resistance ammeter < 15 Ω) |
|--|--|

2.5 Operating conditions

The percentages refer to the configured measuring span.

Supply voltage influence/load influence: within the specified limits for the voltage/load the total influence is less than 0.001% per volt

Common-mode interference no influence up to 100 V Veff (50 Hz) or 50 VDC

Ambient temperature influence: based on 23 °C / 73.4 °F (ambient temperature range: -40 ... 85 °C / -40 °F ... 185 °F)

Sensor	Ambient temperature influence For 1 °C / 1.8 °F dev. to 23 °C / 73,4 °F for digital readings	Ambient temperature influence ¹⁾ For 1 °C / 1.8 °F dev. to 23 °C / 73,4 °F for D/A converter
2-, 3-, 4-wire circuit		
RTD Pt10 IEC, JIS, MIL	± 0.04 °C / ± 0.072 °F	± 0.003 %
RTD Pt50 IEC, JIS, MIL	± 0.008 °C / ± 0.014 °F	± 0.003 %
RTD Pt100 IEC, JIS, MIL	± 0.004 °C / ± 0.007 °F	± 0.003 %
RTD Pt200 IEC, MIL	± 0.02 °C / ± 0.036 °F	± 0.003 %
RTD Pt1000 IEC, MIL	± 0.004 °C / ± 0.007 °F	± 0.003 %
RTD Ni50 DIN 43760	± 0.008 °C / ± 0.014 °F	± 0.003 %
RTD Ni100 DIN 43760	± 0.004 °C / ± 0.007 °F	± 0.003 %
RTD Ni120 DIN 43760	± 0.003 °C / ± 0.005 °F	± 0.003 %
RTD Ni1000 DIN 43760	± 0.004 °C / ± 0.007 °F	± 0.003 %
Resistance measurement 0 ... 500 Ω	± 0.002 Ω	± 0.003 %
Resistance measurement 0 ... 5000 Ω	± 0.02 Ω	± 0.003 %
Thermoelement for all defined types	± [(0.001% x (ME[mV] / MS[mV]) + (100% x (0.009 °C / MS [°C])) ¹⁾	± 0.003 %
Voltage measurement -125 ... 125 mV	± 1.5 µV	± 0.003 %
-125 ... 1100 mV	± 15 µV	± 0.003 %

¹⁾ percentages refer to the configured measuring span
ME - Measuring end, MS - Measuring span

Example 1

Pt100 configured measuring range 0 ... 100 °C, (measuring span 100 °C), ambient temperature 33 °C

Dev. from standard temperature: 33 ... 23 °C (reference) = 10 °C

Affect of ambient temperature on digital measurement: 10 °C x ± 0.004 °C / °C = ± 0.04 °C

Affect of ambient temperature on D/A converter: 10 °C x (± 0.003 % / °C) x (100 °C / 100 %) = ± 0.03 °C

Example 2

TC type K, conf. measuring range 0 ... 1000 °C, (measuring span 1000 °C), ambient temperature 33 °C

Measuring start 0 °C corresponds to 0.0 mV; measuring end = 1000 °C corresponds to 41.6 mV; measuring span = 1000 °C or 41.6 mV

Dev. from standard temperature: 33 ... 23 °C (reference) = 10 °C

Affect of ambient temperature on digital measurement: 10 °C x [(± 0.001% x 41.6 mV / 41.6 mV) + (100% x ± 0.009 °C / 1000°C)] x (1000°C / 100%) / °C = ± 0.19 °C

Affect of ambient temperature on D/A converter: 10 °C x [± 0.003 % x 1000 °C / 100 %] / °C = ± 0.3 °C

Worst case total error analysis

Max. possible total error = SQR [(digital accuracy)² + (D/A accuracy) + (digital value temp. influence) + (D/A temp. influence)]

Example 1: Pt100, 0 ... 100°C at 33 °C ambient temperature = $\sqrt{(0.08\text{ °C})^2 + (0.05\text{ °C})^2 + (0.04\text{ °C})^2 + (0.03\text{ °C})^2} = 0.10\text{ °C}$

Example 2: Thermoelement type K, 0 ... 1000 °C at 33 °C ambient temperature = $\sqrt{(0.35\text{ °C})^2 + (0.50\text{ °C})^2 + (0.19\text{ °C})^2 + (0.3\text{ °C})^2} = 0.70\text{ °C}$
(without reference junction error)

2.6 Mechanical design

- Dimensions:** Refer to dimensioned drawings
Weight: 180 g
Material:
- Housing: Plastic polyamide
 - Color: gray RAL9002
- Installation conditions:**
- Mounting orientation No limitations
 - Installation options: 35 mm rail mounting acc. to EN 60175
- Electrical connection:**
- Connection terminals with screw connections, plug-in
 - Lines up to max. 2.5 mm²

3 Communication

HART protocol version 5

The system is registered with the HART Communication Foundation.

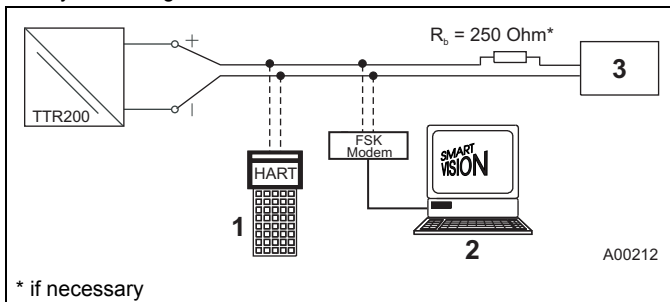

Fig. 3

- | | |
|----------------------|------------------------------------|
| 1 Hand-held terminal | 3 Ground connection (optional) |
| 2 FDT/DTM technology | 4 Power supply (process interface) |

Operating modes

- Point-to-point communication mode: standard (general address 0)
- Multidrop mode (addressing 1 ... 15)

Configuration options and tools

- FDT/DTM technology – via TTX200 DTM driver
- DSV401 (SMART VISION)
- EDD - via TTX200 EDD driver

Configuration parameters

Measurement type

- Sensor type, connection type
- Fault signaling
- Flow range
- General information, e.g., TAG number
- Damping
- Signal simulation of output
- See "Order form configuration"

Write Protection

- Hardware write protection via DIP switch

Diagnostic signaling

- Optical via LEDs, red/green (red LED: sensor & unit fault signaling green LED: supply voltage display)
- Over/underdrive acc. to NE43
- HART diagnostic

Diagnostic information (NE107)

- Sensor error (wire break or short circuit)
- Device error
- Over/under measuring range
- Simulation activated

4 Explosion-protection relevant information

4.1 TTR200-E1... (intrinsically safe)

Approved for use in zone 0.

Designation:

- II 1G EEx ia IIC T6 (Zone 0)
- II 2 (1) G EEx [ia] ib IIC T6 (zone 1 [0])
- II 2 G (1D) Ex [iaD] ib IIC T6 (zone 1 [20])



Important

The Ex or ignition-proof designation is provided on the name plate.

EC prototype test certificate: Refer to PTB 05 ATEX2017 X.

Temperature table

Temperature class	Permissible ambient temperature range	
	Device category 1 use	Device category 2 use
T6	-40 ... 44 °C	-40 ... 56 °C
T5	-40 ... 56 °C	-40 ... 71 °C
T4, T3, T2, T1	-40 ... 60 °C	-40 ... 85 °C

Safety specifications

Intrinsically safe EEx ia IIC explosion protection

	Supply circuit	Measurement current circuit / passive transducer (RTD)	Measurement current circuit / active transducer (RTD)
Max. voltage	$U_i = 30 \text{ V}$	$U_o = 6,5 \text{ V}$	$U_o = 1,2 \text{ V}$
Short-circuit current	$I_i = 130 \text{ mA}$	$I_o = 25 \text{ mA}$	$I_o = 50 \text{ mA}$
Max. power	$P_i = 0,8 \text{ W}$	$P_o = 38 \text{ mW}$	$P_o = 60 \text{ mW}$
Internal inductance	$L_i = 0,5 \text{ mH}$	$L_i = 0 \text{ mH}$	$L_i = 0 \text{ mH}$
Internal capacitance	$C_i = 5 \text{ nF}$	$C_i = 49 \text{ nF}$	$C_i = 49 \text{ nF}$
Maximum permissible external inductance		$L_o = 5 \text{ mH}$	$L_o = 5 \text{ mH}$
Maximum permissible external capacitance		$C_o = 1,55 \text{ }\mu\text{F}$	$C_o = 1,05 \text{ }\mu\text{F}$

4.2 TTR200-E2... (non-incendive)

Approved for use in zone 2.

Designation:

- II 3 G EEx n A II T6



Important

The Ex or ignition-proof designation is provided on the name plate.

ABB manufacturer's declaration in accordance with ATEX directive

Temperature table

Temp.- class	Device category 2 use
T6	-40 ... 56 °C
T5	-40 ... 71 °C
T4	-40 ... 85 °C

5 Approvals

CE mark:

The TTR200 meets all requirements for the CE mark in accordance with IEC 61326 (2006).

Ignition protection:

The TTR200 complies with the requirements of ATEX directive 94/9 EC. For additional information, refer to the section "Explosion-protection relevant information").

6 Terminal connection diagrams

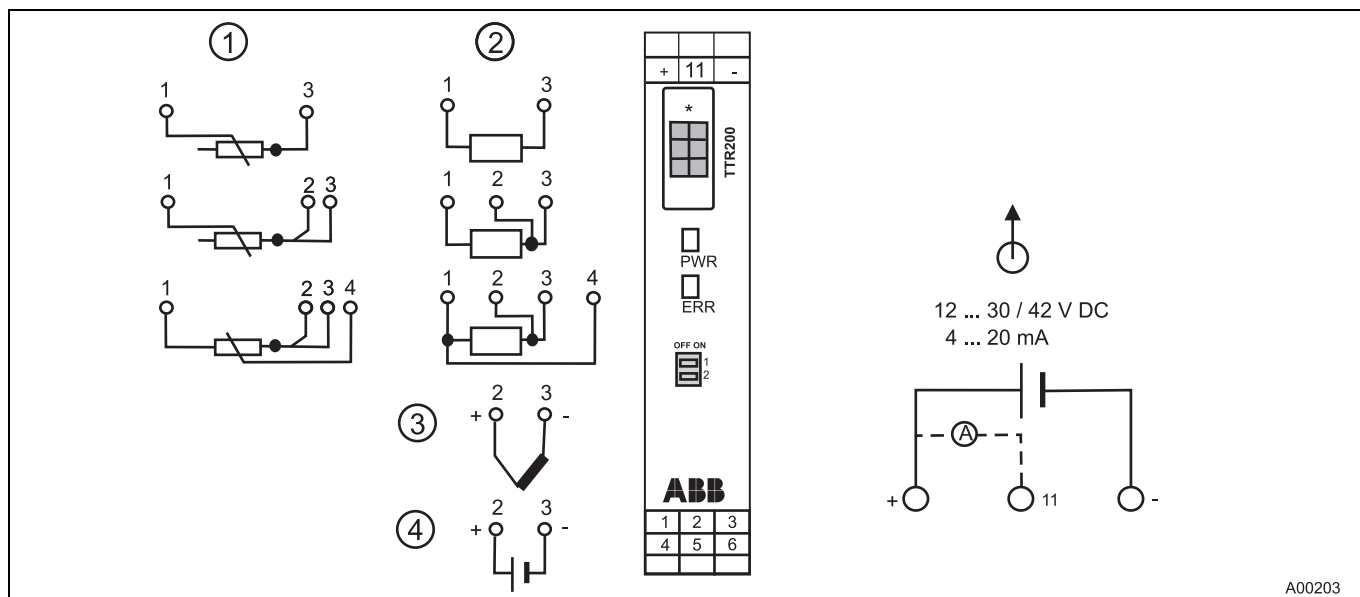

Fig. 4: *(planned local configuration interface/inoperable)

- | | |
|--------------------|-----------------------|
| 1 Potentiometer | 3 Thermocouple |
| 2 RTD (e.g. Pt100) | 4 Voltage measurement |

Note

Terminal 11: Measurement of 4 ... 20 mA output current without opening / interrupting the current loop (see chapter 2.4.1 Block diagram).

- PWR / green LED: Supply voltage display
- ERR / red LED: sensor, sensor lead & unit fault signaling

- DIP switch 1: on -> Hardware write protection is enabled
- DIP switch 2: no function

7 Dimensional drawings

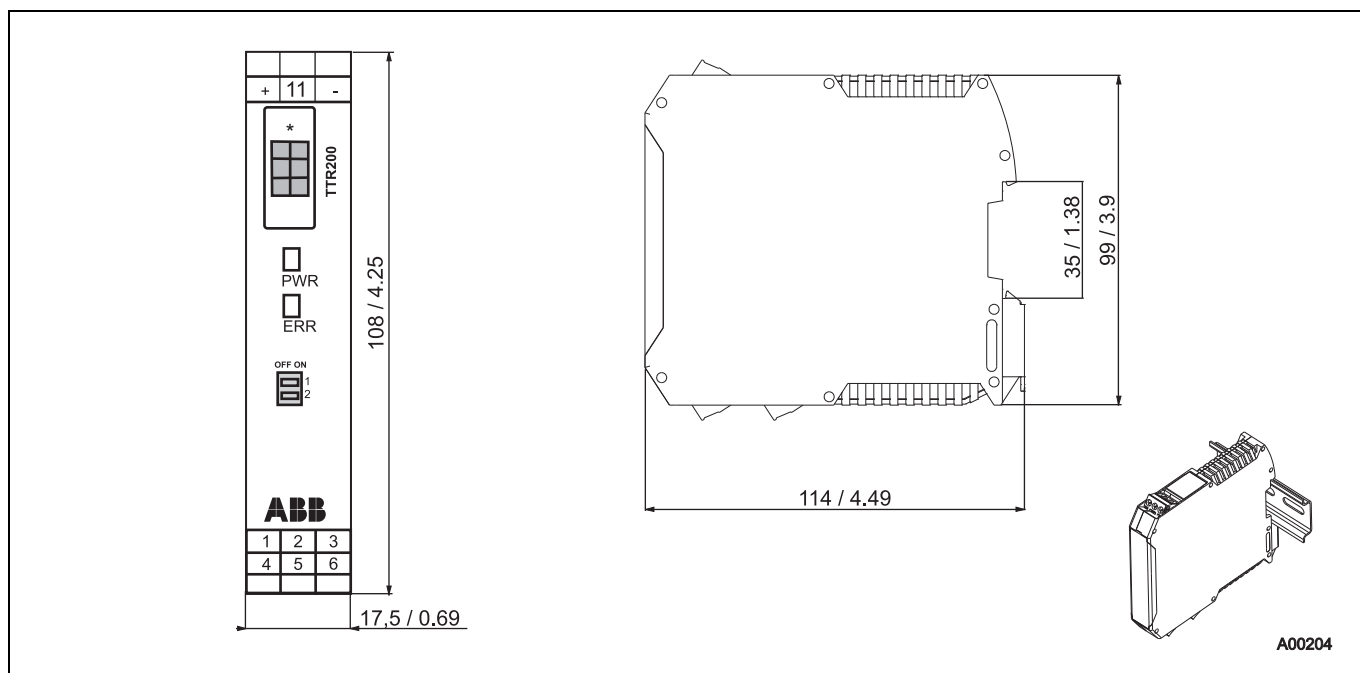

Fig. 5: Dimensions in mm / inch

- 1 Rail housing for mounting on 35 mm rail acc. to EN 60175

8 Ordering information

Rail mounted Temperature Transmitter TTR200 Standard configuration: Pt100 3-wire circuit, 0 ... 100 °C, Damping off, rising characteristic Override for sensor or device errors (>= 22 mA)	Variant digit No.	1 - 7	8	9	10	Code			
	Catalog No.	TTR200-							
Explosion protection No ignition protection			Y	0					
Ignition protection type: Intrinsic Safety ATEX ATEX Zone 0: II 1G EEx ia IIC T6 Zone 1 (0): II 2 (1) G EEx [ia] ib IIC T6 Zone 1 (20): II 2 G (1D) Ex [iaD] ib IIC T6			E	1					
Type of Protection: "nA" (Non Incendive) ATEX ATEX Zone 2: II 3G EEx nA II T6			E	2					
Communication protocol HART						H			
Additional ordering information									
						Code			
Configuration Customer-specific configuration with report						BF			
Calibration certificate With 5-point - factory calibration certificate						EM			
Customer specific design according to NL no. (please specify)						Z9			

9 Order form configuration

Information on customer-specific configuration of temperature transmitter TTR200.

Configuration		Selection
DIN IEC 60 751	RTD	<input type="checkbox"/> Pt10 <input type="checkbox"/> Pt50 <input type="checkbox"/> Pt100 (standard)
JIS C1604-81		<input type="checkbox"/> Pt200 <input type="checkbox"/> Pt500 <input type="checkbox"/> Pt1000
MIL-T-24388		<input type="checkbox"/> Pt10 <input type="checkbox"/> Pt50 <input type="checkbox"/> Pt100
DIN 43760		<input type="checkbox"/> Pt10 <input type="checkbox"/> Pt50 <input type="checkbox"/> Pt100 <input type="checkbox"/> Pt200 <input type="checkbox"/> Pt1000
Cu		<input type="checkbox"/> Ni50 <input type="checkbox"/> Ni100 <input type="checkbox"/> Ni120 <input type="checkbox"/> Ni1000 <input type="checkbox"/> Cu10 <input type="checkbox"/> Cu100
	Linear resistance measurement	<input type="checkbox"/> 0 ... 500 Ω <input type="checkbox"/> 0 ... 5000 Ω
IEC 584	Thermocouple	<input type="checkbox"/> Type K <input type="checkbox"/> Type J <input type="checkbox"/> Type N <input type="checkbox"/> Type R <input type="checkbox"/> Type S <input type="checkbox"/> Type T <input type="checkbox"/> Type E <input type="checkbox"/> Type B
DIN 43710		<input type="checkbox"/> Type L <input type="checkbox"/> Type U
ASTME 988		<input type="checkbox"/> Type C <input type="checkbox"/> Type D
	Linear voltage measurement	<input type="checkbox"/> -125 ... 125 mV <input type="checkbox"/> -125 ... 1100 mV
Sensor circuit (for RTD + resistance measurement only)		<input type="checkbox"/> 2-wire <input type="checkbox"/> 3-wire (standard) <input type="checkbox"/> 4-wire 2-wire circuit: Compensation of sensor-wire resistance max. 100 Ω <input type="checkbox"/>Ω
Reference junction (for thermocouples only)		<input type="checkbox"/> Internal (for standard thermocouple, except type B) <input type="checkbox"/> no (TC type B) <input type="checkbox"/> External/temp.:.....°C
Flow range		<input type="checkbox"/> Measurement start: (Standard: 0) <input type="checkbox"/> Measurement end: (Standard: 100)
Unit		<input type="checkbox"/> Celsius (standard) <input type="checkbox"/> Fahrenheit <input type="checkbox"/> Rankine <input type="checkbox"/> Kelvin
Characteristic behavior		<input type="checkbox"/> rising 4 ... 20mA (standard) <input type="checkbox"/> falling 20 ... 4mA
Output behavior for error		<input type="checkbox"/> Override/22 mA (standard) <input type="checkbox"/> Underdrive/3.6 mA
Output attenuation (T ₆₃)		<input type="checkbox"/> Off (standard) <input type="checkbox"/> Seconds (1 ... 100 s)
Sensor number		<input type="checkbox"/> (max. 8 characters)
TAG number		<input type="checkbox"/> (max. 8 characters)
Software write protection		<input type="checkbox"/> Off (standard) <input type="checkbox"/> On

ABB has Sales & Customer Support
expertise in over 100 countries worldwide.

www.abb.com/temperature

The Company's policy is one of continuous product
improvement and the right is reserved to modify the
information contained herein without notice.

Printed in the Fed. Rep. of Germany (07.2008)

© ABB 2008

3KXT241001R1001



ABB Limited
Salterbeck Trading Estate
Workington, Cumbria
CA14 5DS
UK
Tel: +44 (0)1946 830 611
Fax: +44 (0)1946 832 661

ABB Inc.
125 E. County Line Road
Warminster, PA 18974
USA
Tel: +1 215 674 6000
Fax: +1 215 674 7183

ABB Automation Products GmbH
Borsigstr. 2
63755 Alzenau
Germany
Tel: +49 551 905-534
Fax: +49 551 905-555
CCC-support.deapr@de.abb.com